

FEATURES

- 12-Bit, 250 MWPS Digital-to-Analog Converter
- ECL Compatibility
- Low Glitch Energy: 15 pV-s
- Low Power: 600 mW
- 40 MHz Multiplying Bandwidth
- Master-Slave Latches
- Industrial Temperature Range

APPLICATIONS

- Fast Frequency Hopping Spread Spectrum Radios
- Direct Sequence Spread Spectrum Radios
- Microwave and Satellite Modems
- Test & Measurement Instrumentation
- Military Applications

GENERAL DESCRIPTION

The SPT5310 is a 12-bit, 250 MWPS digital-to-analog converter designed for direct digital synthesis, high resolution imaging and arbitrary waveform generation applications. The SPT5310 is an ECL-compatible device. It features a low glitch

impulse energy of 15 pV-s that results in excellent spurious free dynamic range characteristics.

The SPT5310 is available in 28-lead plastic DIPs and 28-lead PLCCs in the industrial temperature range (-40 to +85 °C).

BLOCK DIAGRAM

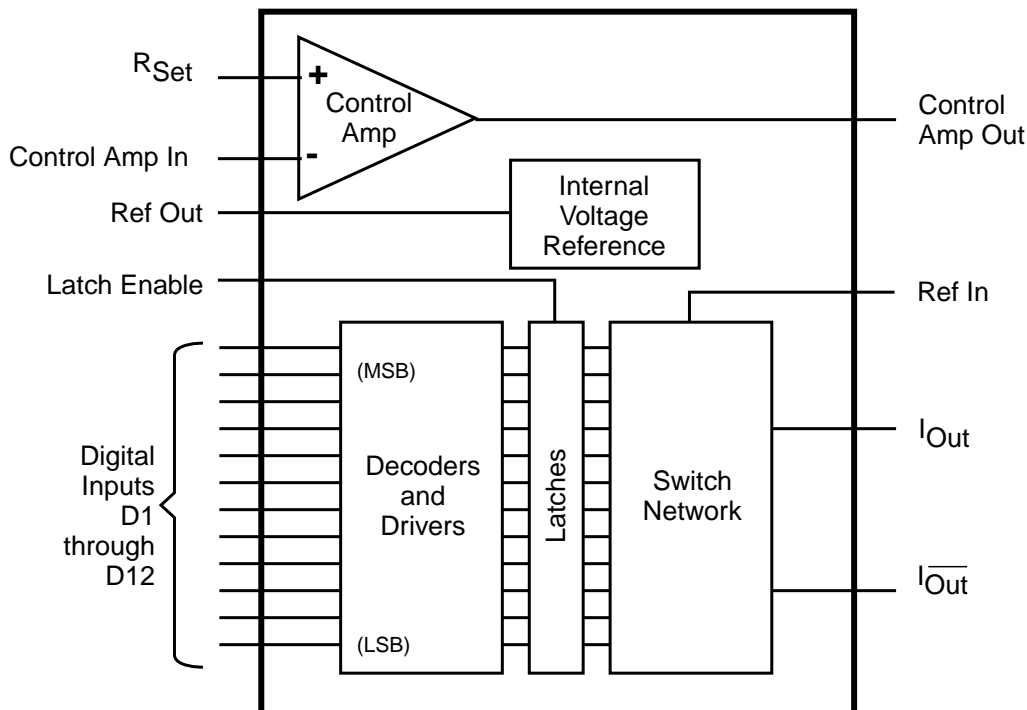

Signal Processing Technologies, Inc.

4755 Forge Road, Colorado Springs, Colorado 80907, USA

Phone: (719) 528-2300 FAX: (719) 528-2370

ABSOLUTE MAXIMUM RATING (Beyond which damage may occur)¹

Supply Voltages

Negative Supply Voltage (V _{EE})	-7 V
A/D Ground Voltage Differential	0.5 V

Input Voltages

Digital Input Voltage (D1-D12, Latch Enable)	0 V to V _{EE}
Control Amp Input Voltage Range	0 V to -4 V
Reference Input Voltage Range (V _{REF})	-3.7 V to V _{EE}

Output Currents

Internal Reference Output Current	500 μA
Control Amplifier Output Current	±2.5 mA

Temperature

Operating Temperature	-40 to + 85 °C
Junction Temperature	+ 150 °C
Lead, Soldering (10 seconds)	+ 300 °C
Storage	-65 to + 150 °C

Note: 1. Operation at any Absolute Maximum Ratings is not implied. See Electrical Specifications for proper nominal applied conditions in typical applications.

ELECTRICAL SPECIFICATIONS

T_A = T_{min} - T_{max}, V_{EE} = -5.2 V, R_{SET} = 7.5 kΩ, Control Amp In = Ref Out, V_{OUT} = 0 V, unless otherwise specified.

PARAMETERS	TEST CONDITIONS	TEST LEVEL	SPT5310			UNITS
			MIN	TYP	MAX	
DC Performance						
Resolution				12		Bits
Differential Linearity		I		±1.0	±1.25	LSB
Differential Linearity	Max at Full Temp.	VI			±2.0	LSB
Integral Linearity	Best Fit	I		±1.0	±1.5	LSB
Integral Linearity	Max at Full Temp.	VI			±2.0	LSB
Output Capacitance	+25 °C			10		pF
Gain Error ¹	+25 °C	I		1.0	5.0	% FS
	Full Temp.	VI			8.0	% FS
Gain Error Tempco	Full Temp.	V		150		PPM/°C
Zero-Scale Offset Error	+25 °C	I		0.5	2.5	μA
	Full Temp.	VI			5.0	μA
Offset Drift Coefficient	Full Temp.	V		0.01		μA/°C
Output Compliance Voltage	+25 °C	IV	-1.2		+2.0	V
Equivalent Output Resistance	+25 °C	IV	0.8	1.0	1.2	kΩ
Dynamic Performance						
Conversion Rate	+25 °C	IV	250			MWPS
Settling Time t _{ST} ²	+25 °C	V		13		ns
Output Propagation Delay t _D ³	+25 °C	V		1		ns
Glitch Energy ⁴	+25 °C	V		15		pV-s
Full Scale Output Current ⁵	+25 °C	V		20.48		mA

¹Gain is measured as a ratio of the full-scale current to I_{SET}. The ratio is nominally 128.

²Measured as voltage at mid-scale transition to ±0.024%; R_L=50 Ω.

³Measured from the rising edge of Latch Enable to where the output signal has left a 1 LSB error band.

⁴Glitch is measured as the largest single transient.

⁵Calculated using $I_{FS} = 128 \times \left(\frac{\text{Control Amp In}}{R_{SET}} \right)$

⁶SFDR is defined as the difference in signal energy between the fundamental and worst case spurious frequencies in the output spectrum window, which is centered at the fundamental frequency and covers the indicated span.

ELECTRICAL SPECIFICATIONS

$T_A = T_{min} - T_{max}$, $V_{EE} = -5.2\text{ V}$, $R_{SET} = 7.5\text{ k}\Omega$, Control Amp In = Ref Out, $V_{OUT} = 0\text{ V}$, unless otherwise specified.

PARAMETERS	TEST CONDITIONS	TEST LEVEL	SPT5310			UNITS
			MIN	TYP	MAX	
Dyanmic Performance						
Spurious-Free Dynamic Range ⁶	+25 °C					
5.055 MHz; 20 MWPS	2 MHz Span	V		63		dBc
10.055 MHz; 40 MWPS	2 MHz Span	V		58		dBc
20.055 MHz; 80 MWPS	2 MHz Span	V		56		dBc
40.055 MHz; 160 MWPS	2 MHz Span	V		54		dBc
60.055 MHz; 240 MWPS	2 MHz Span	V		46		dBc
Rise Time / Fall Time	$R_L = 50\ \Omega$	V		2		ns
Power Supply Requirements						
Negative Supply Voltage		IV	-5.46	-5.2	-4.94	V
Negative Supply Current (-5.2 V)	+25 °C	I		115	140	mA
	Full Temp	VI			148	mA
Nominal Power Dissipation		V		600		mW
Power Supply Rejection Ratio	$\pm 5\%$ of V_{EE} External Ref, +25 °C	I		30	100	$\mu\text{A/V}$
Voltage Input and Control						
Reference Input Impedance	+25 °C	V		3		k Ω
Ref. Multiplying Bandwidth	+25 °C	V		40		MHz
Internal Reference Voltage		VI	-1.15	-1.20	-1.25	V
Internal Reference Voltage Drift		V		50		ppm/°C
Amplifier Input Impedance	+25 °C	V		3		M Ω
Amplifier Input Bandwidth	+25 °C	V		1		MHz
Digital Inputs						
Logic 1 Voltage	Full Temp.	VI	-1.0	-0.8		V
Logic 0 Voltage	Full Temp.	VI		-1.7	-1.5	V
Logic 1 Current	Full Temp.	VI			20	μA
Logic 0 Current	Full Temp.	VI			10	μA
Input Capacitance	+25 °C	V		3		pF
Input Setup Time - t_S	+25 °C	IV	3	2		ns
Input Setup Time - t_S	Full Temp.	IV	3.5			ns
Input Hold Time - t_H	+25 °C	IV	0.5	0		ns
Input Hold Time - t_H	Full Temp.	IV	0.5			ns
Latch Pulse Width - t_{PWL} , t_{PWH}	+25 °C	IV	4.0	3.3		ns

TEST LEVEL CODES

All electrical characteristics are subject to the following conditions: All parameters having min/max specifications are guaranteed. The Test Level column indicates the specific device testing actually performed during production and Quality Assurance inspection. Any blank section in the data column indicates that the specification is not tested at the specified condition.

TEST LEVEL

- I
- II
- III
- IV
- V
- VI

TEST PROCEDURE

- 100% production tested at the specified temperature.
- 100% production tested at $T_A = 25\text{ °C}$, and sample tested at the specified temperatures.
- QA sample tested only at the specified temperatures.
- Parameter is guaranteed (but not tested) by design and characterization data.
- Parameter is a typical value for information purposes only.
- 100% production tested at $T_A = 25\text{ °C}$. Parameter is guaranteed over specified temperature range.

THEORY OF OPERATION

The SPT5310 uses a segmented architecture incorporating most significant bit (MSB) decoding. The four MSBs (D1-D4) are decoded to thermometer code lines to drive 15 discrete current sinks. For the eight least significant bits (LSBs), D5 and D6 are binary weighted and D7-D12 are applied to the R-2R network. The 12-bit decoded data is input to internal master/slave latches. The latched data is input to the switching network and is presented on the output pins as complementary current outputs.

TYPICAL INTERFACE CIRCUIT

The SPT5310 requires few external components to achieve the stated operation and performance. Figure 2 shows the typical interface requirements when using the SPT5310 in normal circuit operation. The following sections provide descriptions of the pin functions and outlines critical performance criteria to consider for achieving optimal device performance.

POWER SUPPLIES AND GROUNDING

The SPT5310 requires the use of a single -5.2 V supply. All supplies should be treated as analog supply sources. This means the ground returns of the device should be connected to the analog ground plane. All supply pins should be bypassed with .01 μF and 10 μF decoupling capacitors as close to the device as possible.

The two grounds available on the SPT5310 are DGND and AGND. These grounds are not tied together internal to the device. The use of ground planes is recommended to achieve the best performance of the SPT5310. All ground, reference and analog output pins should be tied to directly to the DAC ground plane. The DAC and system ground planes should be separate from each other and only connected at a single point through a ferrite bead to reduce ground noise pickup.

DIGITAL INPUTS AND TIMING

The SPT5310 uses single-ended, 10K ECL-compatible inputs for data inputs D1-D12 and Latch Enable. It also employs master/slave latches to simplify digital interface timing requirements and reduce glitch energy by synchronizing the current switches. This is an improvement over the AD5310, which typically requires external latches for digital input synchronization.

Referring to figure 1, data is latched into the DAC on the rising edge of the latch enable clock with the associated setup and hold times. The output transition occurs after a typical 1 ns propagation delay and settles to within ± 1 LSB in typically 13 ns. Because of the SPT5310's rising edge-triggering, no timing changes are required when replacing an AD5310 operating in nontransparent mode.

VOLTAGE REFERENCE

When using the internal reference, Ref Out should be connected to Control Amp In and decoupled with a 0.1 μF capacitor. Control Amp Out should be connected to Ref In and decoupled to the analog supply. (See figure 2.)

Full-scale output current is determined by Control Amp In and R_{Set} using the following formula:

$$I_{\text{Out}}(\text{FS}) = (\text{Control Amp In} / R_{\text{Set}}) \times 128$$

(Current out is a constant 128 factor of the reference current)

The internal reference is typically -1.20 V with a tolerance of ± 0.05 V and a typical drift of 50 ppm/ $^{\circ}\text{C}$. If greater accuracy or temperature stability is required, an external reference can be utilized.

OUTPUTS

The output of the SPT5310 is comprised of complementary current sinks, I_{Out} and $\overline{I_{\text{Out}}}$. The output current levels at either I_{Out} or $\overline{I_{\text{Out}}}$ are based upon the digital input code. The sum of the two is always equal to the full-scale output current minus one LSB.

By terminating the output current through a resistive load to ground, an associated voltage develops. The effective resistive load (R_{Eff}) is the output resistance of the device (R_{Out}) in parallel with the resistive load (R_{L}). The voltage which develops can be determined using the following formulas:

$$\begin{aligned} \text{Control Amp Out} &= -1.2 \text{ V, and } R_{\text{Set}} = 7.5 \text{ k}\Omega \\ I_{\text{Out}}(\text{FS}) &= (-1.2 \text{ V} / 7.5 \text{ k}\Omega) \times 128 = -20.48 \text{ mA} \\ R_{\text{L}} &= 51 \Omega \\ R_{\text{Out}} &= 1.0 \text{ k}\Omega \\ R_{\text{Eff}} &= 51 \Omega \parallel 1.0 \text{ k}\Omega = 48.52 \Omega \\ V_{\text{Out}} &= R_{\text{Eff}} \times I_{\text{Out}}(\text{FS}) = 48.52 \Omega \times -20.48 \text{ mA} \\ &= -0.994 \text{ V} \end{aligned}$$

The resistive load of the SPT5310 can be modified to incorporate a wide variety of signal levels. However, optimal device performance is achieved when the outputs are equivalently loaded.

Figure 1 - Timing Diagram

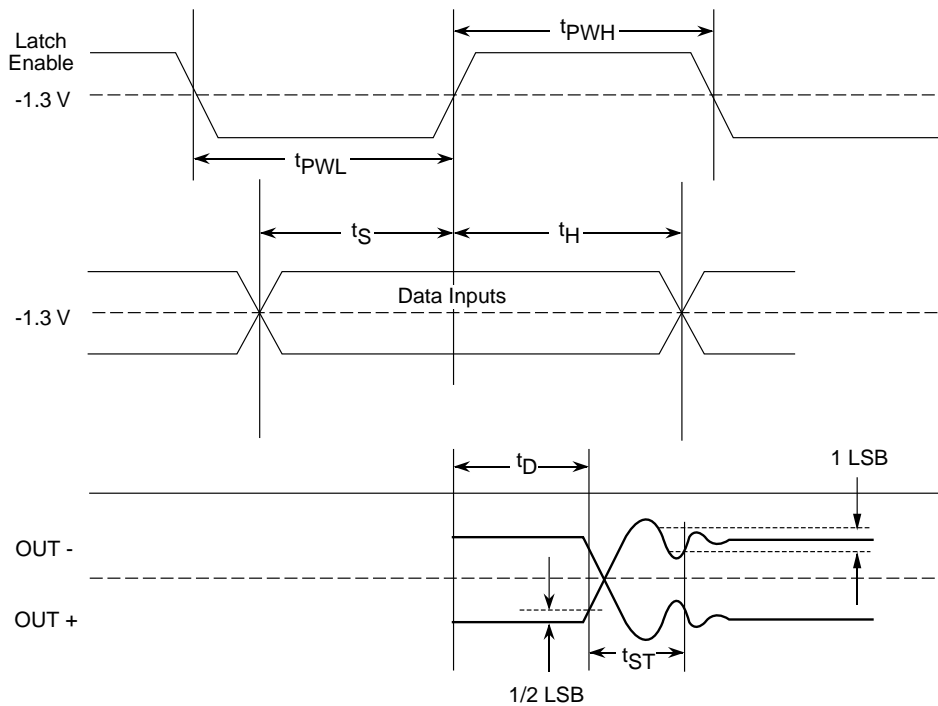
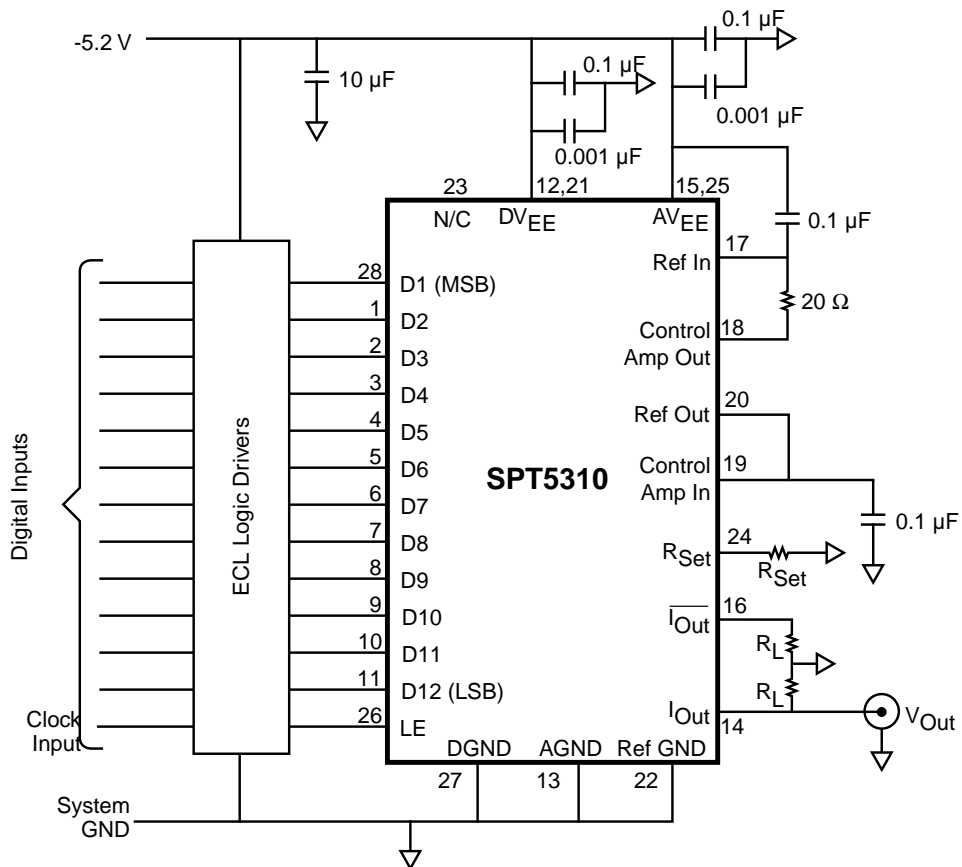

Figure 2 - Typical Interface Circuit



PACKAGE OUTLINES

28L Plastic DIP

SYMBOL	INCHES		MILLIMETERS	
	MIN	MAX	MIN	MAX
A		0.200		5.08
B	0.120	0.135	3.05	3.43
C		0.020		0.51
D		0.100		2.54
E		0.067		1.70
F		0.013		0.33
G	0.170	0.180	4.32	4.57
H		0.622		15.80
I		0.555		14.10
J		1.460		37.08
K		0.085		2.16

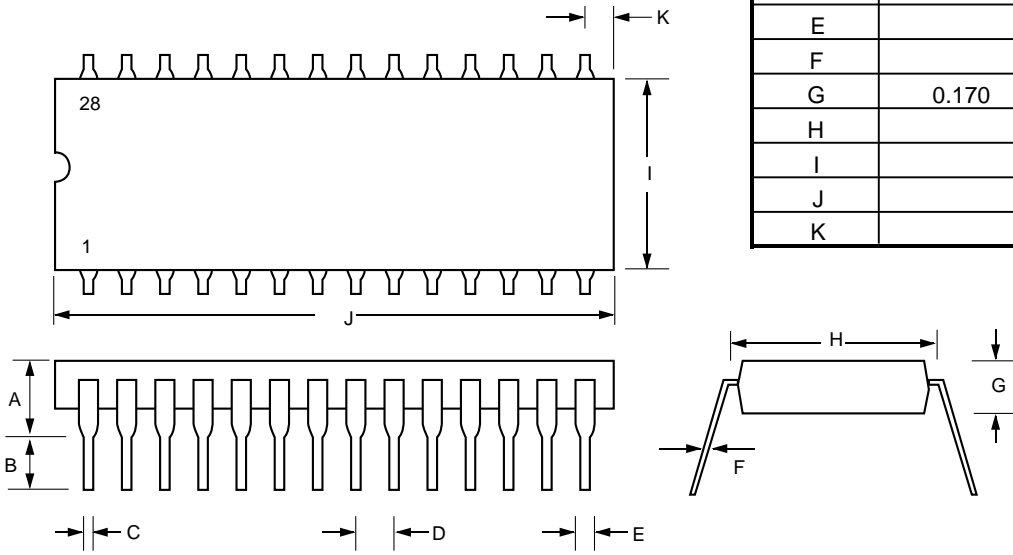

PACKAGE OUTLINES

28L PLCC

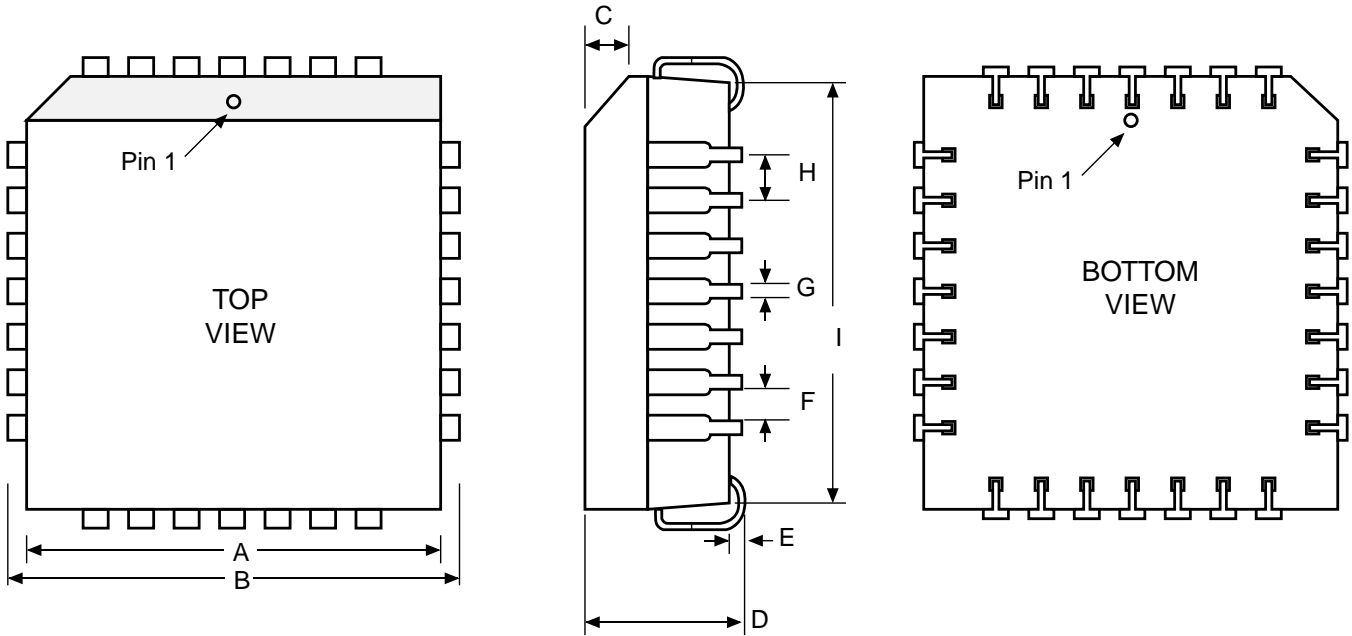

SYMBOL	INCHES		MILLIMETERS	
	MIN	MAX	MIN	MAX
A	0.450	0.456	11.43	11.58
B	0.485	0.495	12.32	12.57
C	45°		45°	
D	0.165	0.175	4.19	4.45
E		0.010		0.25
F	0.022 typ		.56 typ	
G	0.18 typ		4.57 typ	
H	0.05 typ		1.27 typ	
I	0.039	0.430	0.99	10.92

PIN ASSIGNMENTS

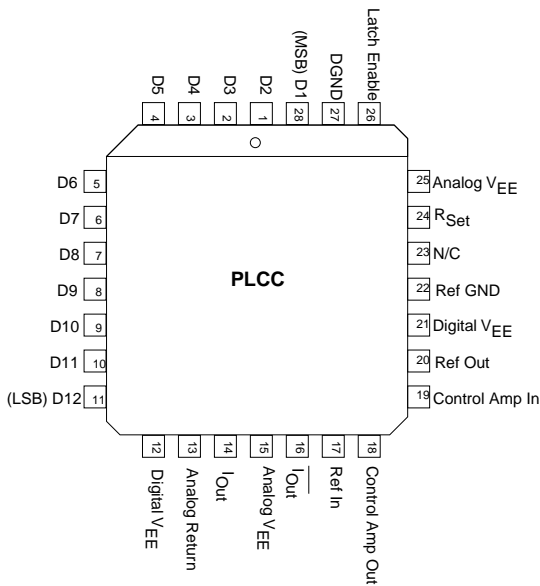
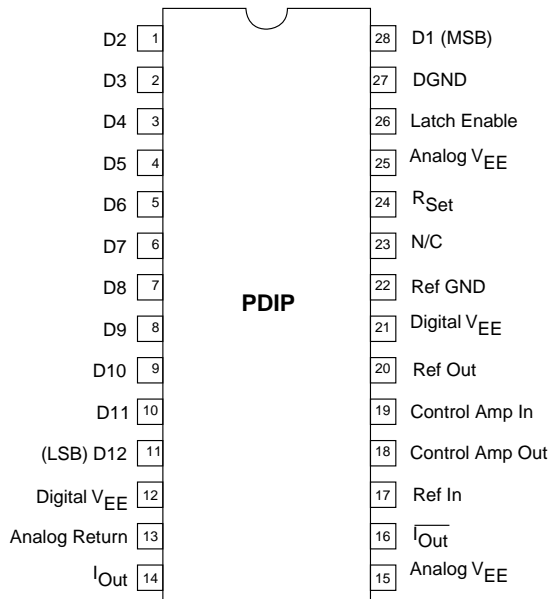

PIN FUNCTIONS

Name	Function
Out+	Analog Current Output
Out-	Complementary Analog Current Output
D1-D12	Digital Input Bits (D12 is the LSB)
Latch Enable	Latch Control Line
Ref In	Voltage Reference Input
Ref Out	Internal Voltage Reference Output Normally Connected to Control Amp In
Ref GND	Ground Return For Internal Voltage Reference and Amplifier
Control Amp In	Normally Connected to Ref Out If Not Connected to External Reference
Control Amp Out	Output of Internal Control Amplifier Normally Connected to Ref In
RSet ¹	Connection for External Resistance Reference When Using Internal Amplifier Nominally 7.5 kΩ
Analog Return	Analog Return Ground
Analog VEE	Analog Negative Supply (-5.2 V)
Digital VEE	Digital Negative Supply (-5.2 V)
DGND	Digital Ground Return
N/C	Not Connected

¹Full-Scale Current Out=128 (Control Amp In/RSet)

ORDERING INFORMATION

PART NUMBER	DNL/INL	PACKAGE
SPT5310 SIN	±1.25/±1.5	28L PDIP
SPT5310 SIP	±1.25/±1.5	28L PLCC

Signal Processing Technologies, Inc. reserves the right to change products and specifications without notice. Permission is hereby expressly granted to copy this literature for informational purposes only. Copying this material for any other use is strictly prohibited.

WARNING - LIFE SUPPORT APPLICATIONS POLICY - SPT products should not be used within Life Support Systems without the specific written consent of SPT. A Life Support System is a product or system intended to support or sustain life which, if it fails, can be reasonably expected to result in significant personal injury or death.

Signal Processing Technologies believes that ultrasonic cleaning of its products may damage the wire bonding, leading to device failure. It is therefore not recommended, and exposure of a device to such a process will void the product warranty.